

Dual Constant Current Step-Down Switching Converter

1 Features

- 4.2V to 32V wide operating input range
- 2.0V to 32V wide operating output range
- Integrated two 13mΩ power MOSFETs.
- Dynamical programming of output current and Output voltage using PWM signal or analog signal
- Adjustable Switching Frequency using resistor
- Frequency dithering for good EMI performance
- Integrated 2-A MOSFET Gate Drivers
- Comprehensive protection features including Output Short Protection (OSP), Cycle-by-Cycle Peak Current Limit, thermal regulation, thermal shutdown, input UVLO, output OVP etc.
- Dual Output Average Current Limiting with stable CC loop
- QFN5x5-32 Package

2 Applications

- Automotive Start-Stop Systems
- Industrial PC Power Supplies
- USB Power Delivery

3 Description

PL84052 is a PWM controller, designed for high performance synchronous Buck DC/DC applications with input voltages 4.2V to 32V.

PL84052 employs Constant ON time control. The switching frequency could be set to 150kHz, 300kHz based on different resistor value between FREQ pin and GND pin. The device also features a programmable soft-start function and offers all kinds of protection features including cycle-by-cycle current limiting, input under voltage lockout (UVLO), output over voltage protection (OVP), thermal shutdown and output short protection etc.

PL84052 provides voltage control loop, constant current loop, and thermal regulation loop.

4 Typical Application Schematic

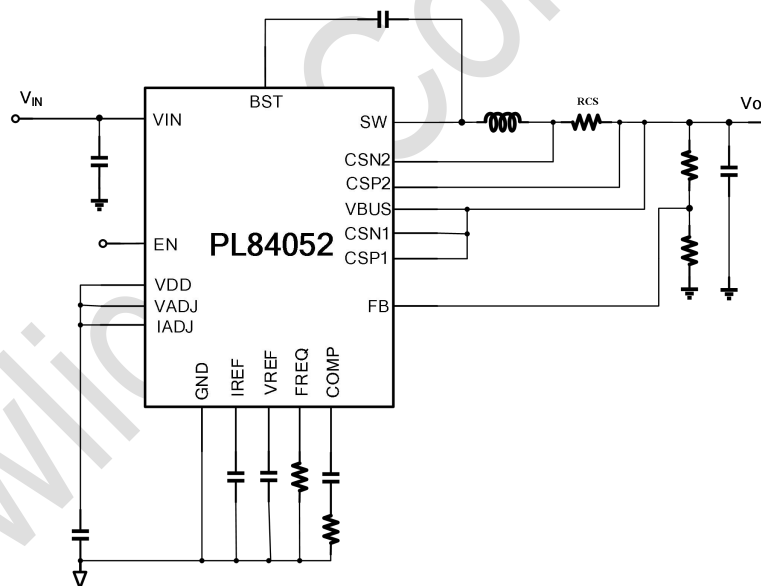
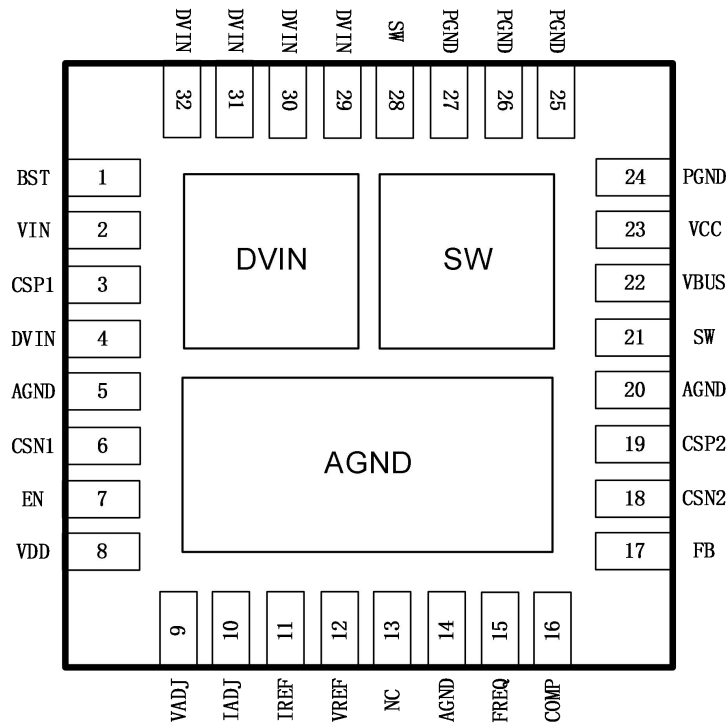

Fig. 4-1 Application Schematic

5 Pin Configuration and Functions

Fig. 5-1 Pin-Function (QFN5x5-32)

Pin		Description
Number	Name	
1	BST	Boost pin for high side MOSFET driver.
2,4,29,30,31,32	VIN	Input voltage.
3	CSP1	The positive input of output1 current sense.
24,25,26,27	PGND	Power Ground.
6	CSN1	The minus input of output1 current sense.
7	EN	Logic High will enable the converter. Pull Low or Float to disable.
8	VDD	5.4V power supply for PL84052 control core.
9	VADJ	Connect a 0-2V analog voltage or a PWM signal to program voltage reference on VREF pin. Connect this pin to VDD will force VREF to constant 2V.
10	IADJ	Connect a 0-2V analog voltage or a PWM signal to program voltage reference on IREF pin. Connect this pin to VDD will force IREF to 2V.
11	IREF	Reference voltage for output current limiting loop.
12	VREF	Voltage reference for voltage control loop
13	NC	NC
5,14,20	AGND	Analog ground. Connect PGND and AGND together at the thermal pad under IC.
15	FREQ	Connect to GND to set the switching frequency at 150kHz. Connect this pin to VDD or Float to set switching frequency at 300kHz.It is recommended to use 150 KHZ.
16	COMP	Error Amplifier output.
17	FB	VBUS voltage feedback. Connect a resistor divider between VBUS and GND to FB to program VBUS voltage.
18	CSN2	The minus input of output2 current sense.
19	CSP2	The positive input of output2 current sense.
21,28	SW	Connect this pin to the Switching point of the power stage.
22	VBUS	VBUS voltage.
23	VCC	5.0V power supply for high side and low side driver.

6 Device Marking Information

Order Information	Label Part NO.	Package	Package Qty	Top Marking
PL84052	PL84052IQN32A	QFN5x5 - 32	5000	84052 RAAYMD

PL84052: Part Number

RAAYMD: RAA: LOT NO.; YMD: Package Date Code

7 Specifications

7.1 Absolute Maximum Ratings^(Note1)

PARAMETER	MIN	MAX	Unit
VIN, VBUS, CSN, CSP, SW	-0.3	40	V
HG, BST to SW	-0.3	7	
LG, VCC to GND	-0.3	7	
CSP to CSN	-0.3	0.6	
VBUS to CSP, CSN	-0.3	0.6	
Other Pins to GND	-0.3	6	

7.2 Handling Ratings

PARAMETER	DEFINITION	MIN	MAX	UNIT
T _{ST}	Storage Temperature Range	-65	150	°C
T _J	Junction Temperature		+150	°C
T _L	Lead Temperature		+260	°C
V _{ESD}	HBM Human body model		2	kV

7.3 Recommended Operating Conditions^(Note 2)

	PARAMETER	MIN	MAX	Unit
Input Voltages	VIN, VBUS	4.2	32	V
Temperature	Operating junction temperature range, T _J	-40	+125	°C

7.4 Thermal Information^(Note 3)

Symbol	Description	QFN5x5-32	Unit
θ _{JA}	Junction to ambient thermal resistance	44	°C/W
θ _{JC}	Junction to case thermal resistance	9	

Notes:

- 1) Exceeding these ratings may damage the device.
- 2) The device function is not guaranteed outside of the recommended operating conditions.
- 3) Measured on approximately 1" square of 1 oz copper.

7.5 Electrical Characteristics (Typical at VIN = 12V, TJ = 25°C, unless otherwise noted.)

Supply voltages	PARAMETER	CONDITION	MIN	TYP	MAX	UNIT
VIN	Input voltage		4.2		32	V
IQ_VIN	VIN Shutdown Current	EN=0V, VIN=7.2V		15		uA
	VIN Supply Current	No Switching, FB=2.1V		1000		uA
VBUS	Bus line voltage		2		30	V
VVCC	Driver power supply voltage	VIN =15V		5.0		V
VVDD	Control core power supply voltage	VIN =15V		5.4		V
UVLO/EN						
VIN_UV	VINUVLO Rising			4.2		V
	UVLO Hysteresis			300		mV
VEN_UV	Operation Threshold		1.1	1.2	1.3	V
	Hysteresis			200		mV
VVREF		VADJ connected to VDD		2.013		V
Control loop						
VFB	VFB regulation voltage in discharging mode	FB voltage		2.013		V
Dmax	Maximum Duty Cycle ^(Note 4)			98.5		%
GmEA	Error amplifier gm			450		uS
ISINK	COMP sink/source current	VFB=VREF+100mV		15		uA
ISOURCE	COMP source current	VFB=VREF-100mV		20		uA
IFB	FB bias current	FB2 in regulation		100		nA
Frequency						
FSW	Switching Frequency	FREQ 0-0.4V, short FREQ pin to GND.		150		KHz
		FREQ 1.8-5.4V, short FREQ pin to VDD.		300		KHz
Current Limit						
ICCLIM_BUS	Bus average current Limit, VCSP - VCSN			40		mV
POWER SWITCHES						
RdSON-HS	High-side MOSFET RDSON	ISW = -100 mA		13		mΩ
RdSON-LS	Low-side MOSFET RDSON	ISW = -100 mA		13		mΩ
VBSTUV	UVLO			2		V
	UVLO Hysteresis			300		mV
Output Protection						
VOVP	Output over voltage threshold			110		%
VUVP	Output under voltage threshold			50		%
VADJ, IADJ						
VTH_VADJ ^(Note 4)	VPWM low voltage			0.4		V
	VPWM high voltage		2.5			V
VTH_IADJ ^(Note 4)	IPWM low voltage			0.4		V
	IPWM high voltage		2.5			V
TSD ^(Note 4)	Thermal Shutdown Threshold			150		°C
THYS ^(Note 4)	Thermal Shutdown Hysteresis			20		°C

Notes:

4) Guaranteed by design.

8 Typical Characteristics

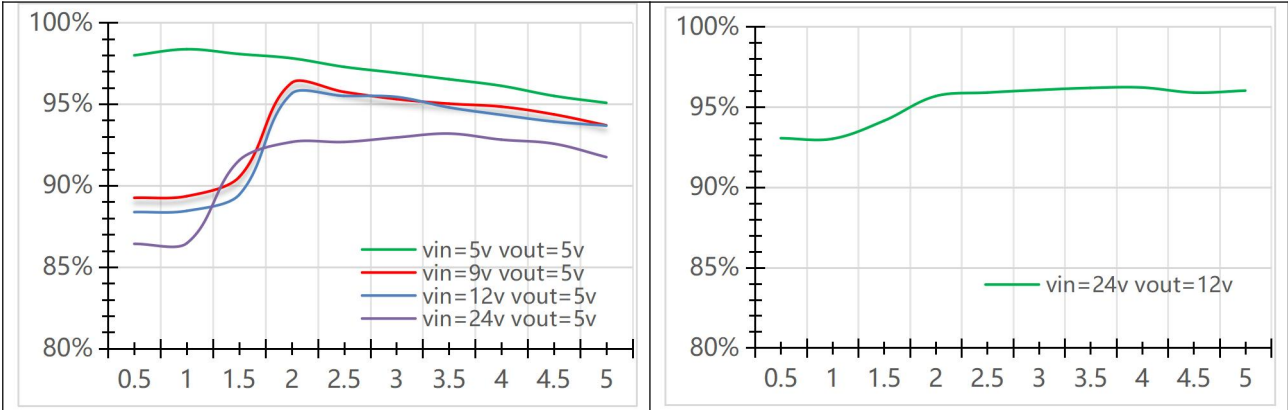

CH1: VIN CH2:VOUT CH3:SW CH4:IL
 Vin=5V Vout=5V
 Start up waveform through Vin, Iout =0A

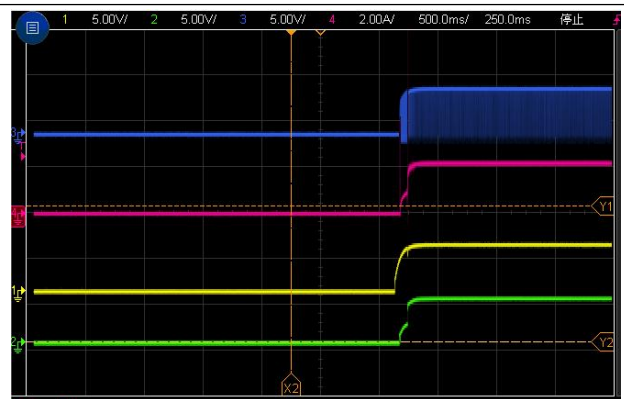

CH1: VIN CH2:VOUT CH3:SW CH4:IL
 Vin=5V Vout=5V
 Start up waveform through Vin, Iout =3A



CH1: VIN CH2:VOUT CH3:SW CH4:IL
 Vin=12V Vout=5V
 Start up waveform through Vin, Iout =0A

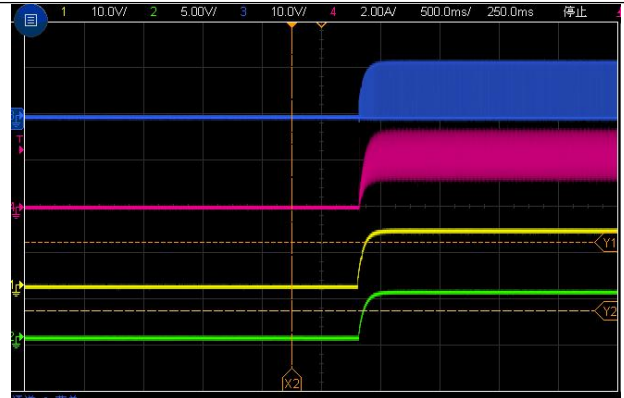

CH1: VIN CH2:VOUT CH3:SW CH4:IL
 Vin=12V Vout=5V
 Start up waveform through Vin, Iout =3A



CH1: VIN CH2:VOUT CH3:SW CH4:IL

Vin=24V Vout=5V

Start up waveform through Vin, Iout =0A

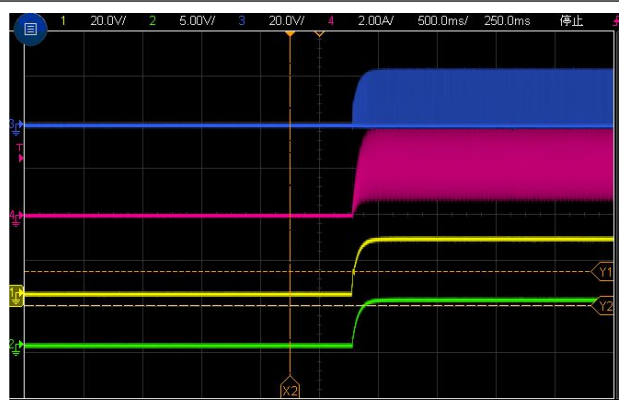

CH1: VIN CH2:VOUT CH3:SW CH4:IL

Vin=24V Vout=5V

Start up waveform through Vin, Iout =3A

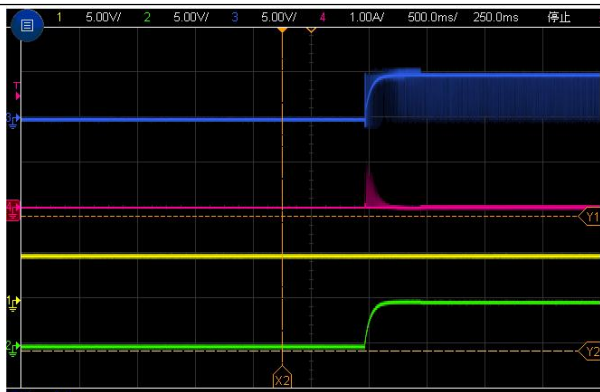

CH1: VIN CH2:VOUT CH3:SW CH4:IL

Vin=5V Vout=5V

Start up waveform through EN, Iout =0A



CH1: VIN CH2:VOUT CH3:SW CH4:IL

Vin=5V Vout=5V

Start up waveform through EN, Iout =3A



CH1: VIN CH2:VOUT CH3:SW CH4:IL

Vin=12V Vout=5V

Start up waveform through EN, Iout =0A



CH1: VIN CH2:VOUT CH3:SW CH4:IL

Vin=12V Vout=5V

Start up waveform through EN, Iout =3A



CH1: VIN CH2:VOUT CH3:SW CH4:IL

Vin=24V Vout=5V

Start up waveform through EN, Iout =0A

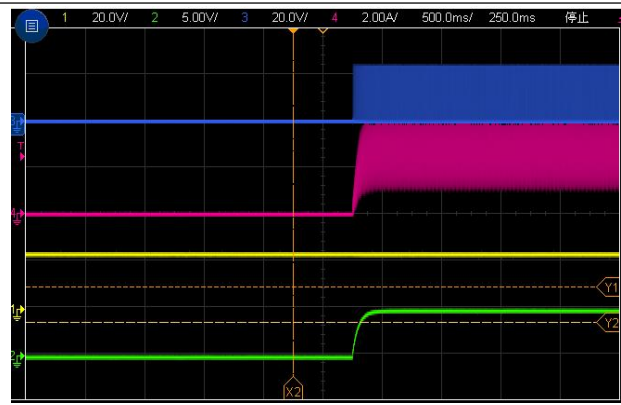

CH1: VIN CH2:VOUT CH3:SW CH4:IL

Vin=24V Vout=5V

Start up waveform through EN, Iout =3A



CH1: VIN CH2:VOUT CH3:SW CH4:IL

Vin=5V Vout=5V

Shut Down waveform through VIN, Iout =0A

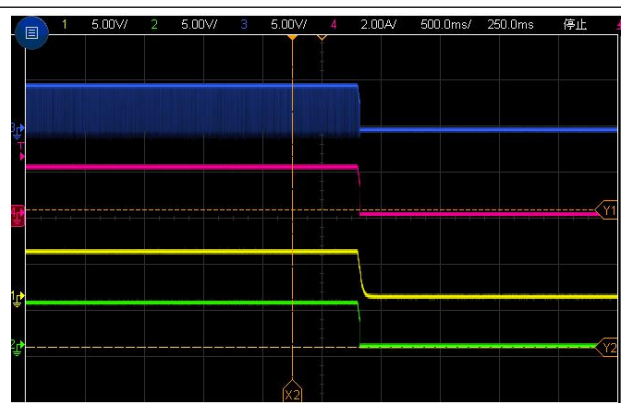

CH1: VIN CH2:VOUT CH3:SW CH4:IL

Vin=5V Vout=5V

Shut Down waveform through VIN, Iout =3A



CH1: VIN CH2:VOUT CH3:SW CH4:IL

Vin=12V Vout=5V

Shut Down waveform through VIN, Iout =0A

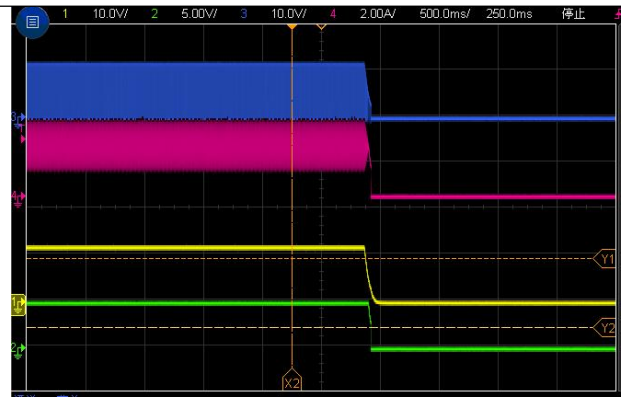

CH1: VIN CH2:VOUT CH3:SW CH4:IL

Vin=12V Vout=5V

Shut Down waveform through VIN, Iout =3A



CH1: VIN CH2:VOUT CH3:SW CH4:IL

Vin=24V Vout=5V

Shut Down waveform through VIN, Iout =0A

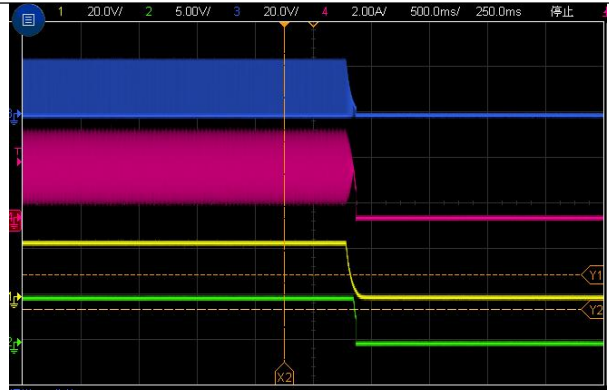

CH1: VIN CH2:VOUT CH3:SW CH4:IL

Vin=24V Vout=5V

Shut Down waveform through VIN, Iout =3A

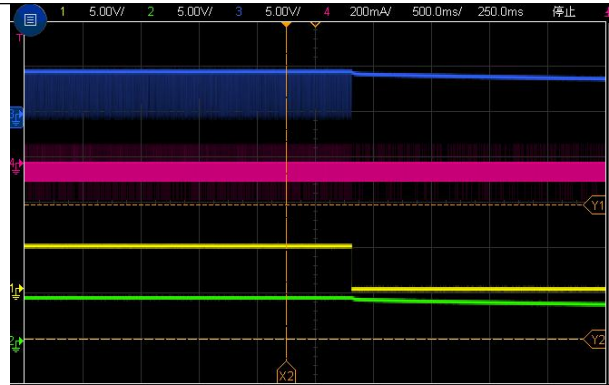

CH1: EN CH2:VOUT CH3:SW CH4:IL

Vin=5V Vout=5V

Shut Down waveform through EN, Iout =0A

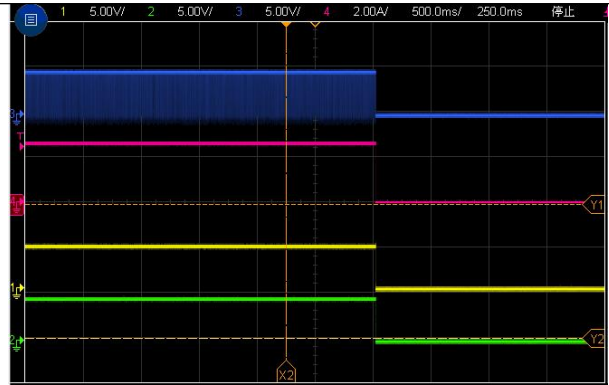

CH1: EN CH2:VOUT CH3:SW CH4:IL

Vin=5V Vout=5V

Shut Down waveform through EN, Iout =3A

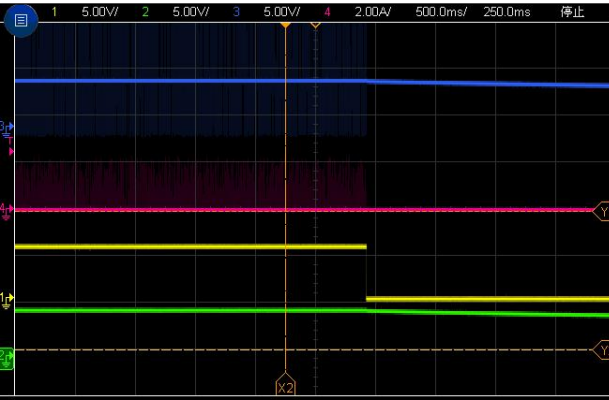

CH1: EN CH2:VOUT CH3:SW CH4:IL

Vin=12V Vout=5V

Shut Down waveform through EN, Iout =0A



CH1: EN CH2:VOUT CH3:SW CH4:IL

Vin=12V Vout=5V

Shut Down waveform through EN, Iout =3A



CH1: EN CH2:VOUT CH3:SW CH4:IL
 Vin=24V Vout=5V
 Shut Down waveform through EN, Iout =0A

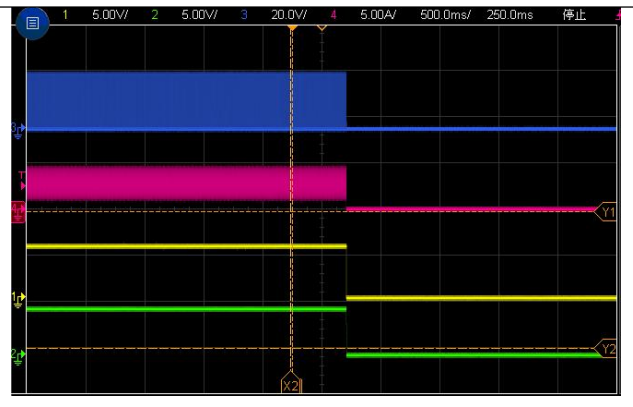

CH1: EN CH2:VOUT CH3:SW CH4:IL
 Vin=24V Vout=5V
 Shut Down waveform through EN, Iout =3A



CH1: VIN CH2:VOUT CH3:SW CH4:IL
 Vin=5V Vout=5V
 Steady State waveform Iout =0A



CH1: VIN CH2:VOUT CH3:SW CH4:IL
 Vin=5V Vout=5V
 Steady State waveform Iout =3A

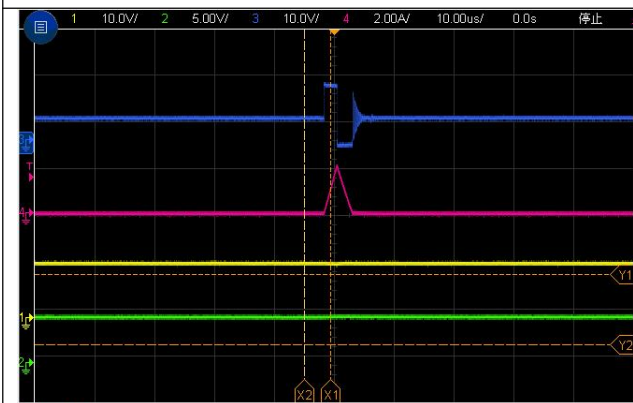

CH1: VIN CH2:VOUT CH3:SW CH4:IL
 Vin=12V Vout=5V
 Steady State waveform Iout =0A

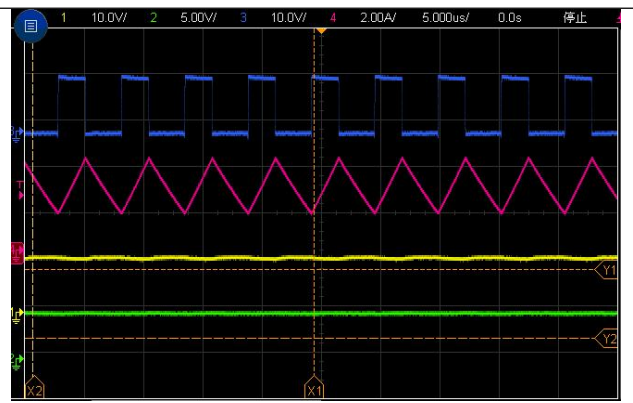

CH1: VIN CH2:VOUT CH3:SW CH4:IL
 Vin=12V Vout=5V
 Steady State waveform Iout =3A



CH1: VIN CH2:VOUT CH3:SW CH4:IL

Vin=24V Vout=5V

Steady State waveform Iout =0A

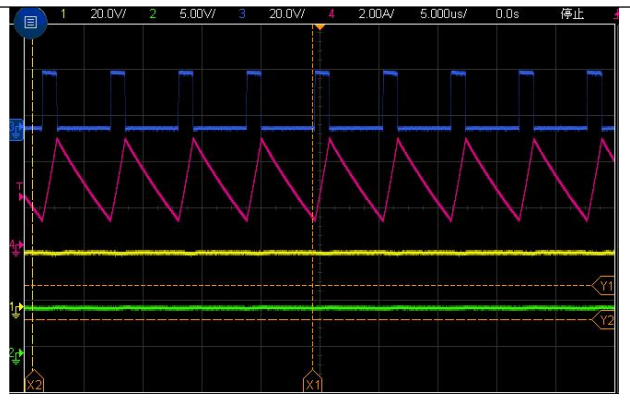

CH1: VIN CH2:VOUT CH3:SW CH4:IL

Vin=24V Vout=5V

Steady State waveform Iout =3A

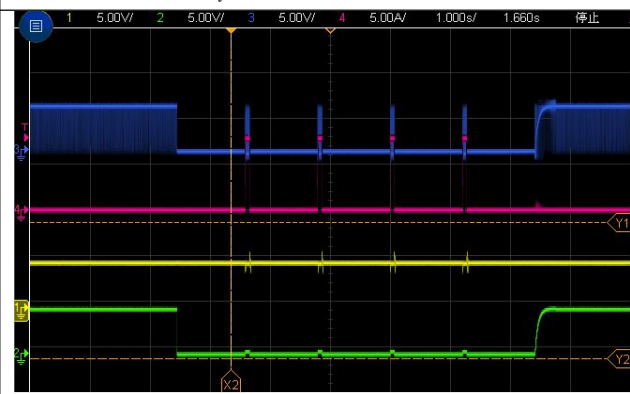

CH1: VIN CH2:VOUT CH3:SW CH4:IL

Vin=5V Vout=5V

Short Circuit waveform Iout =0A



CH1: VIN CH2:VOUT CH3:SW CH4:IL

Vin=12V Vout=5V

Short Circuit waveform Iout =0A



CH1: VIN CH2:VOUT CH3:SW CH4:IL

Vin=24V Vout=5V

Short Circuit waveform Iout =0A

9 Detailed Descriptions

9.1 Overview

PL84052 is a PWM controller, designed for high performance synchronous Buck DC/DC applications with input voltages 4.2 V to 32 V.

PL84052 employs Constant ON time control. The switching frequency could be set to 150kHz, 300kHz based on different resistor value between FREQ pin and GND pin. The device also features a programmable soft-start function and offers all kinds of protection features including cycle-by-cycle current limiting, input under voltage lockout (UVLO), output over voltage protection (OVP), thermal shutdown and output short protection etc.

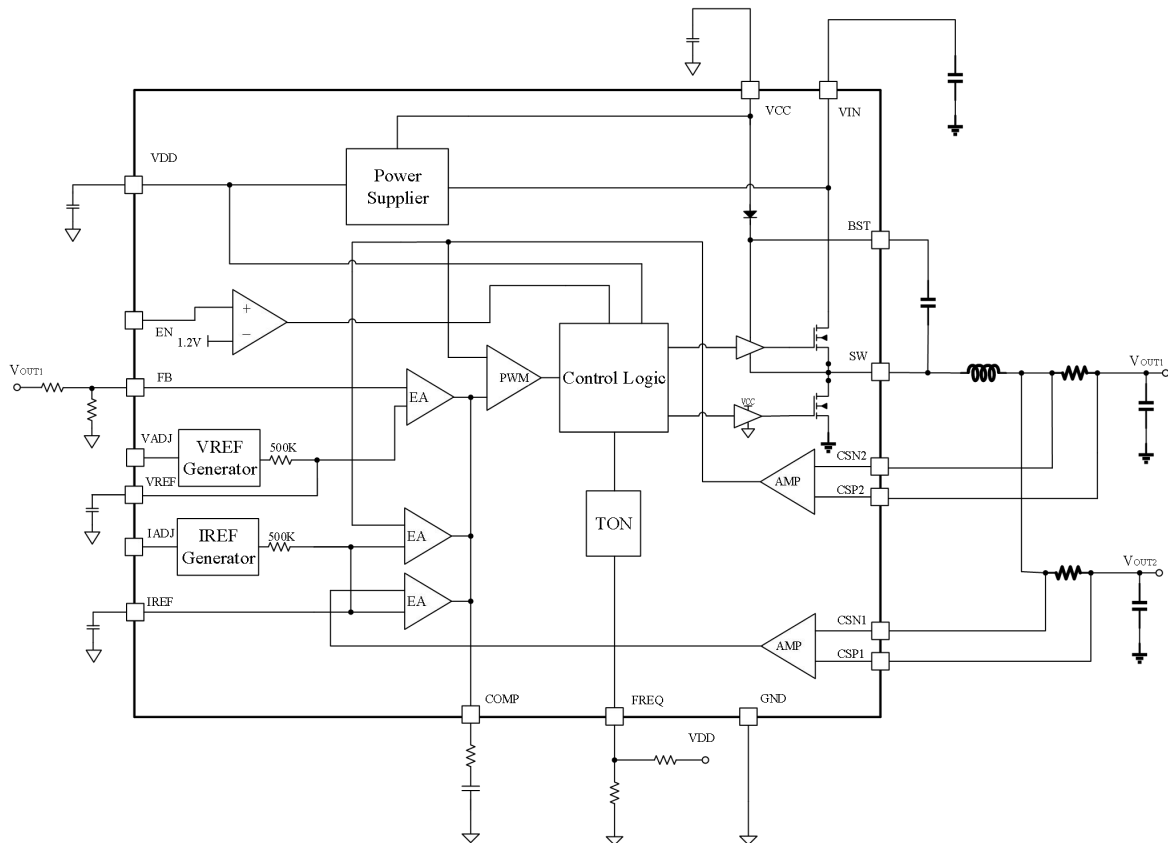

Fig. 9.1-1 Block Diagram

9.2 Enable/UVLO

When EN is greater than 1.2V operating threshold, the control loop starts to work and regulate output to target voltage. When EN pin is below the standby threshold (1.1V typical), PL84052 stops working.

9.3 Over current Protection and short circuit protection

PL84052 provides cycle-by-cycle current limit to protect against over current and short circuit conditions. When VOUT is drop to UV threshold, PL84052 will go into hiccup mode to lower down power consumption.

9.4 Average Output Current Limiting

PL84052 provides optional average current limiting capability to limit either the output current. The average current limiting circuit uses an additional current sense resistor connected in series with the input supply or output voltage of the converter. A current sense gm amplifier with inputs at the CSP and CSN pins monitors the voltage across the sensing resistor and compares it with an internal 40mV reference. If the drop across the sense resistor is greater than 40 mV, the gm amplifier regulates COMP voltage to lower down input or output current. The target constant current is given by Equation 1:

$$I_{CL(AVG)} = \frac{40 \text{ mV}}{R_{SNS}} \quad (1)$$

A resistance of no less than **8mR** is recommended. The average current loop can be disabled by shorting CSP1/CSN1 to VBUS, but CSP2/CSN2 must be used.

9.5 Frequency Setting (FREQ) and frequency dithering

PL84052 switching frequency can be programmed at 150 kHz, 300kHz by voltage at FREQ pin to GND. When FREQ is connected to AGND, the switching frequency is set at 150 kHz. When FREQ is connected to VDD, the switching frequency is set at 300 kHz.

Recommend using 150K to minimize unnecessary EMI generation as much as possible.

9.6 Thermal Shutdown

PL84052 is protected by a thermal shutdown circuit that shuts down the device when the internal junction temperature exceeds 160°C (typical). The soft-start capacitor is discharged when thermal shutdown is triggered and the gate drivers are disabled. The converter automatically restarts when the junction temperature drops by the thermal shutdown hysteresis of 15°C below the thermal shutdown threshold.

9.7 VREF and IREF

VREF pin is the final reference voltage used in the voltage regulation loop. When VADJ is connected to VDD, VREF will be 2V. When VADJ is connected to a PWM signal, PWM signal will first be chopped to 2V and filter out using an internal resistor and external capacitor on VREF pin. The capacitor on VREF pin is also acting as soft-start capacitor at power up or in output voltage transition period. It is recommend using a relatively large capacitor such as 470nF for VREF pin and IREF pin.

The same mechanism works for IADJ and IREF pin.

9.8 VADJ and IADJ

VADJ pin is VBUS Voltage regulation. Support 0-2V DC voltage regulation or PWM signal regulation. When the VADJ pin voltage is greater than or equal to 2.7V, VFB equals 2V, VADJ pin voltage is less than 2V, VFB equals VADJ, If this function is not used, Connect this pin to VDD pin.

IADJ pin is IBUS Current regulation. Support 0-2V DC voltage regulation or PWM signal regulation. If this function is not used, Connect this pin to VDD pin.

10 Applications and Implementation

The typical application on the first page is a basic PL84052 application circuit. External component selection is driven by the load requirement, and begins with the selection of RS1, RS2 and the inductor value. Next, the power MOSFETs need to be selected. Finally, C_{IN} and C_{OUT} are selected. This circuit can be configured for operation up to an input voltage of 32V.

10.1 Inductor Selection

The operating frequency and inductor selection are interrelated in that higher operating frequencies allow the use of smaller inductor and capacitor values. The inductor value has a direct effect on ripple current. The inductor current ripple ΔI_L is typically set to 20% to 40% of the maximum inductor current in the boost region at $V_{IN(MIN)}$.

For a given ripple, the inductance terms in continuous mode are as follows:

$$L > \frac{V_{OUT} * (V_{IN(MAX)} - V_{OUT}) * 1000}{f * \Delta I_L * V_{IN(MAX)}} \mu H \quad (2)$$

where: f is operating frequency, kHz

$V_{IN(MIN)}$ is minimum input voltage, V

$V_{IN(MAX)}$ is maximum input voltage, V

V_{OUT} is output voltage, V

ΔI_L is maximum inductor ripple current, A, usually select 20~40% maximum output current.

For high efficiency, choose an inductor with low core loss, such as ferrite. Also, the inductor should have low DC resistance to reduce the I²R losses, and must be able to handle the peak inductor current without saturating. To minimize radiated noise, use a toroid, pot core or shielded bobbin inductor.

10.2 C_{IN} and C_{OUT} Selection

Input capacitor C_{IN} is driven by the need to filter the input square wave current. Use a low ESR capacitor sized to handle the maximum RMS current, input RMS current is given by:

$$I_{CIN} = I_{OUT(MAX)} * \sqrt{\frac{V_{OUT}}{V_{IN}} * \left(1 - \frac{V_{OUT}}{V_{IN}}\right)} \quad (3)$$

This input current has a maximum at $V_{IN} = 2V_{OUT}$, $I_{CIN(MAX)} = I_{OUT(MAX)}/2$.

The effects of ESR (equivalent series resistance) and the bulk capacitance must be considered when choosing the right capacitor for a given output ripple voltage.

V_{OUT} ripple is given by:

$$\Delta V_{OUT} \leq \Delta I_L * \left(ESR + \frac{1}{8 * f * C_{OUT}}\right) \quad (4)$$

Multiple capacitors placed in parallel may be needed to meet the ESR and RMS current handling requirements.

10.3 Output voltage setting

The PL84052 output voltage is set by an external feedback resistive divider carefully placed across the output capacitor. The 1% resistance accuracy of this resistor divider is preferred. The resultant feedback signal is compared with the internal precision 2V voltage reference by the error amplifier. The output voltage is given by the equation:

$$V_{OUT} = 2V * \left(1 + \frac{R_1}{R_2}\right) \quad (5)$$

Where R₁ is the upper resistor and R₂ is the lower resistor in the feedback network.

11 PCB Layout

11.1 Guideline

Layout is a critical portion of good power supply design. The following guidelines will help users design a PCB with the best power conversion performance, thermal performance, and minimized generation of unwanted EMI.

1. The feedback network, should be kept close to the FB pin. Keep VBUS sensing path away from noisy nodes and preferably through a layer on the other side of shielding layer.
2. The input /output bypass capacitor must be placed as close as possible to the VIN/VBUS pin and ground. Grounding for both the input and output capacitors should consist of localized top side planes that connect to the GND pin and PAD. It is a good practice to place a ceramic cap near the VIN and VBUS pin to reduce the high frequency injection current.
3. Current sensing pairs (CSP,CSN) need to be placed carefully, Layout the lines symmetrically and keep them away from noisy nodes such as BST, SW, HG, LG etc. Connect these nodes directly to the two terminals of current sensing resistors Rcs1, Rcs2 to form an accurate Kelvin connection.

11.2 Application Examples

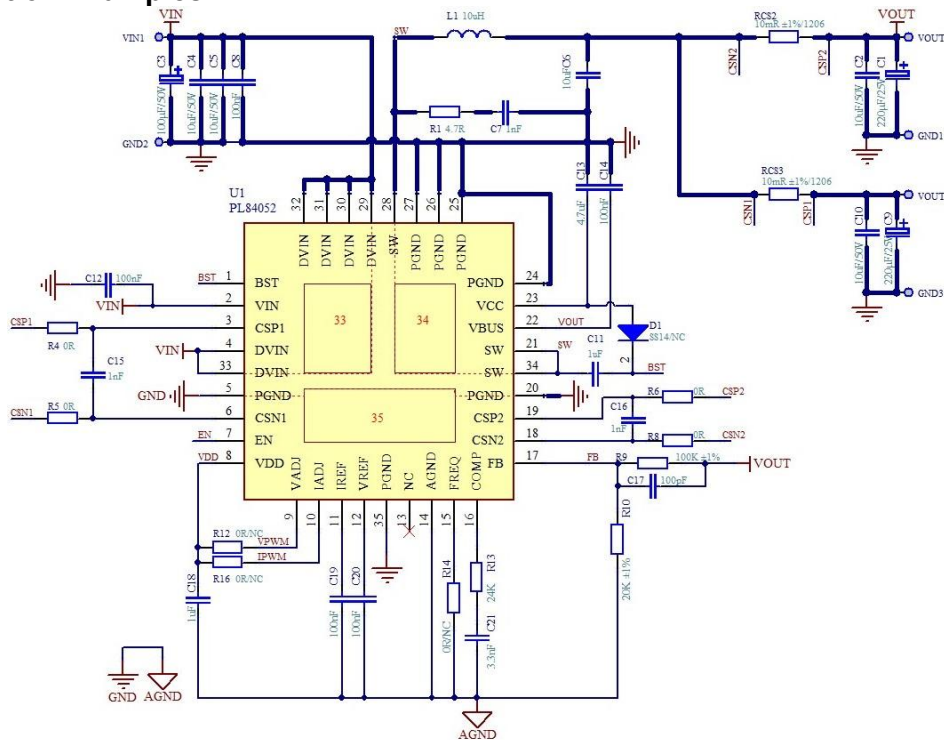

Fig. 11.2-1 Application Schematic

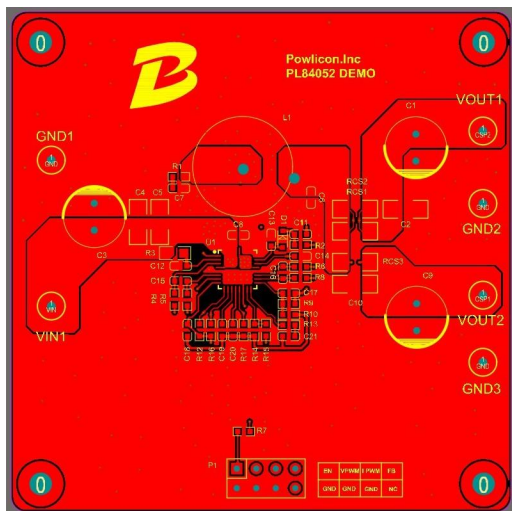

Fig. 11.2-2 Top Layer

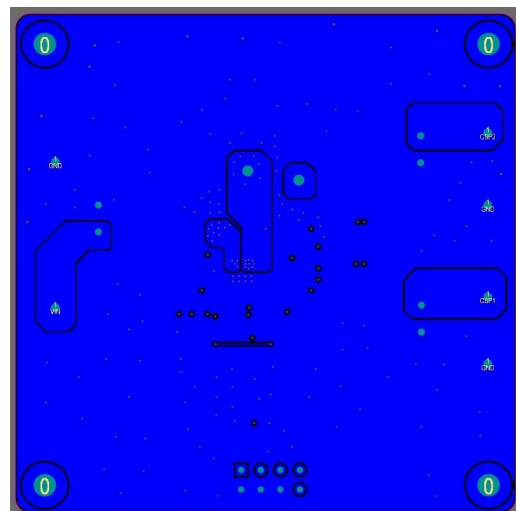

Fig. 11.2-3 Bottom Layer

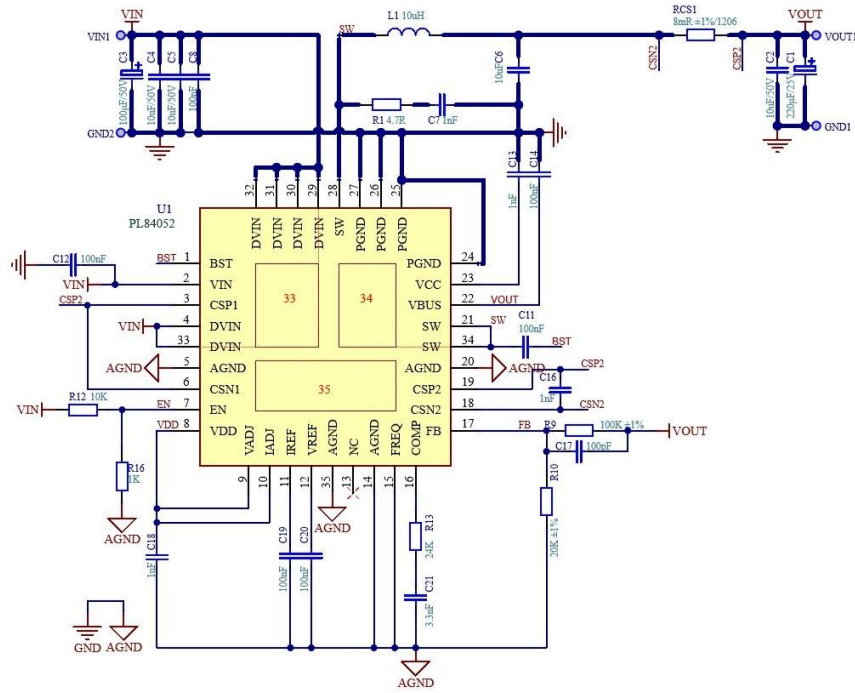
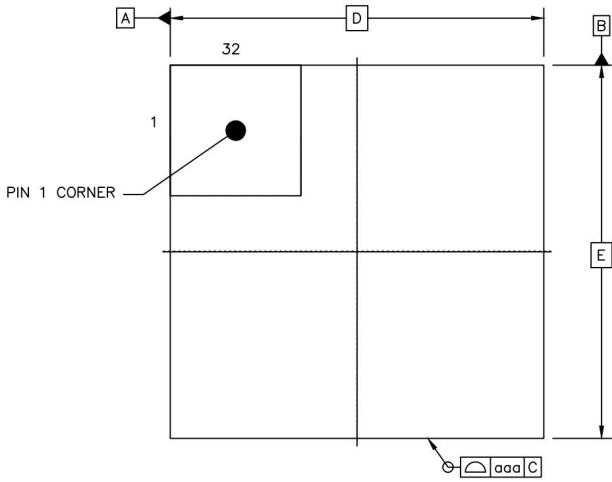

Fig. 11.2-4 Application Schematic

13 Packaging Information



TOP VIEW

	SYMBOL	MIN	NOM	MAX
TOTAL THICKNESS	A	0.7	0.75	0.8
STAND OFF	A1	0	0.02	0.05
MOLD THICKNESS	A2	---	0.55	---
L/F THICKNESS	A3	0.203 REF		
LEAD WIDTH	b	0.2	0.25	0.3
BODY SIZE	X	D		
	Y	E		
LEAD PITCH	e	0.5 BSC		
EP SIZE	X	D2	1.625	1.725
	Y	E2	1.56	1.66
	X	D3	3.7	3.8
	Y	E3	1.69	1.79
LEAD LENGTH	L	0.25	0.35	0.45
LEAD TIP TO EXPOSED PAD EDGE	K	0.25 REF		
	K1	0.35 REF		
PACKAGE EDGE TOLERANCE	aaa	0.1		
MOLD FLATNESS	ccc	0.1		
COPLANARITY	eee	0.08		
LEAD OFFSET	bbb	0.1		
	ddd	0.05		
EXPOSED PAD OFFSET	fff	0.1		

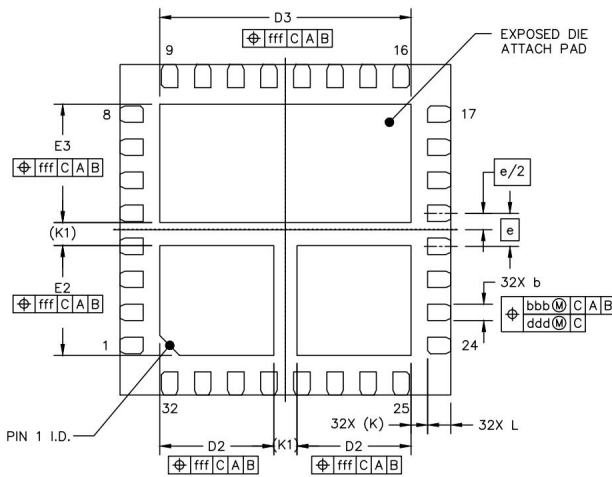

BOTTOM VIEW

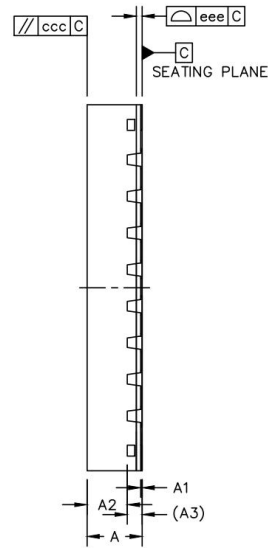

SIDE VIEW

IMPORTANT NOTICE

Powlicon Microelectronics Co. Ltd. assumes no responsibility for any error which may appear in this document. Powlicon Microelectronics Co. Ltd. reserves the right to change devices or specifications detailed herein at any time without notice. Powlicon Microelectronics Co. Ltd. does not assume any liability arising out of the application or use of any product described herein; neither it does it convey any license under its patent rights, nor the rights of others. Powlicon Microelectronics Co. Ltd. products are not authorized for use as critical components in life support devices or systems without written approval letter from the Chief Executive Officer of Powlicon Microelectronics Co. Ltd. The use of products in such applications shall assume all risks of such use and will agree to not hold against Powlicon Microelectronics Co. Ltd. for any damage.